

SAVE-T® Bumpers, Wheel Chocks & Track Guards

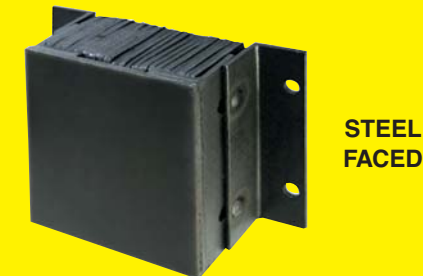

Save-T LAMINATED RUBBER BUMPERS

Laminated Bumpers are constructed of recycled truck tire pads compressed between steel angles and secured with 3/4" steel tie rods. Laminated bumpers, the most common style, protect both trucks and docks. Our complete line includes all sizes from 4-1/2" to 12" thick in horizontal, vertical, extra-length, and extra-thick styles. Gussets for lower loading docks and special sizes are also available.

See Back Cover
for Product
Model Numbers

Save-T STEEL FACED BUMPERS

Steel Faced Bumpers with a 3/8" thick steel front plate should be used where maximum protection is desired. They will absorb more shock and abrasion than standard laminated bumpers, and absorb the constant height adjustment of air ride trailers. Standard sizes are 4-1/4" to 12-3/4" thick in standard design and sizes. Gussets for lower loading docks and special sizes are also available. Steel Faced Bumpers last as much as 5 times longer than standard laminated bumpers, offering the lowest cost of ownership.

Save-T MOLDED RUBBER BUMPERS

Molded Dock Bumpers are manufactured using reinforced rubber in a variety of shapes and sizes. These solid, durable, one piece bumpers are smooth, attractive, and will not harden or be affected by weather. The most popular models are the "T", "L", and "R" styles. We carry a full line of standard sizes.

Save-T EXTRUDED BUMPERS

When wall protection from forklifts and other loading dock equipment is needed, Extruded Bumpers are the ideal solution. This type of bumper is also great for indoor parking areas and marinas. They are available in any length up to ten feet and can have holes pre-drilled at the factory. Common styles include the "D" and "E" shapes.

Save-T WHEEL CHOCKS

TMI, LLC carries an entire line of wheel chocks, including laminated rubber, molded rubber, urethane, and aluminum. Wheel chocks can be purchased with standard chain lengths of 10', 12', and 15'. Safety security signs are also available.

OSHA Regulation 1910.78(M) - Wheel chocks must be used in addition to a trailer stand while trailer is docked.



Save-T OVERHEAD DOOR TRACK GUARDS

Made of heavy-duty 7 gauge steel, they absorb impact from forklifts and other vehicles. Track guards bolt to the floor and the wall for firm attachment.

- Wraps around door track without interfering with door operation
- 45 degree angle flange adds strength and protects from side impact
- 1/4" thick floor plate drilled for three 1/2" anchors
- 3/16" thick wall flange drilled for three 1/2" anchors
- 7-1/4" projection
- Stocked in 36" (DTG 36), and 48" (DTG 48) sections

SAVE-T® Laminated Rubber Bumpers

H – Overall Height
 W – Overall Width
 T – Overall Thickness
 R – Width of Rubber Surface

A – Horizontal Anchor Holes - Center to Center (7/8" Holes)
 B – Vertical Anchor Holes - Center to Center
 C – Center of Anchor Hole to Top/Bottom Edge

DRAWING 1

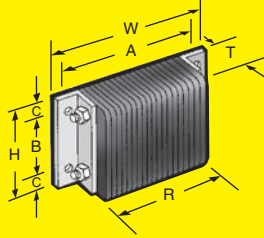

DRAWING 2

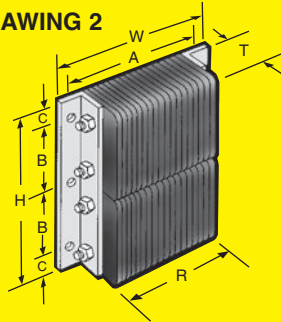

DRAWING 3

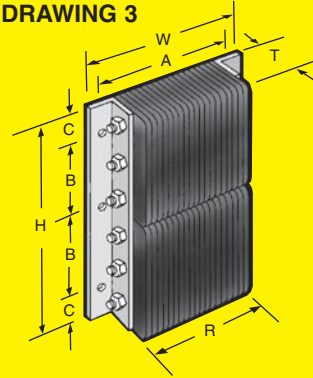

DRAWING 4

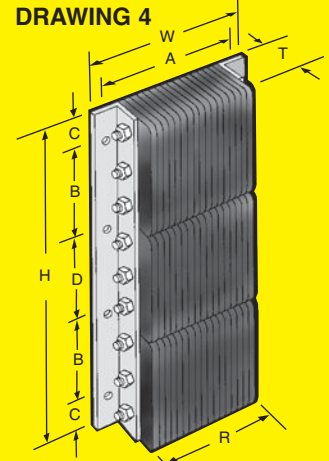

• Structural Steel Angles and Plates - 3/8" Thick

• Add-On for Galvanized Angles - Consult Factory

MODEL NO.	Drawing No.	H	W	T	R	A	B	C	D	Wt.(lbs.)
B410-12	1	10"	14"	4 1/2"	8"	12"	5"	2 1/2"	-	27
B410-14	1	10"	16"	4 1/2"	10"	14"	5"	2 1/2"	-	31
B410-24	1	10"	26"	4 1/2"	20"	24"	5"	2 1/2"	-	48
B410-36	1	10"	38"	4 1/2"	32"	36"	5"	2 1/2"	-	72
B412-12	1	12"	14"	4 1/2"	8"	12"	7"	2 1/2"	-	32
B412-14	1	12"	16"	4 1/2"	10"	14"	7"	2 1/2"	-	36
B412-24	1	12"	26"	4 1/2"	20"	24"	7"	2 1/2"	-	58
B412-36	1	12"	38"	4 1/2"	32"	36"	7"	2 1/2"	-	9
VB420-11	2	20"	13"	4 1/2"	7"	11"	7 1/2"	2 1/2"	-	50
VB424-11	3	24"	13"	4 1/2"	7"	11"	9 1/2"	2 1/2"	-	59
B610-12	1	10"	14"	6"	8"	12"	5"	2 1/2"	-	37
B610-14	1	10"	16"	6"	10"	14"	5"	2 1/2"	-	4
B610-24	1	10"	26"	6"	20"	24"	5"	2 1/2"	-	74
B610-36	1	10"	38"	6"	32"	36"	5"	2 1/2"	-	111
B612-12	1	12"	14"	6"	8"	12"	7"	2 1/2"	-	45
B612-14	1	12"	16"	6"	10"	14"	7"	2 1/2"	-	52
B612-24	1	12"	26"	6"	20"	24"	7"	2 1/2"	-	84
B612-36	1	12"	38"	6"	32"	36"	7"	2 1/2"	-	133
VB620-11	2	20"	13"	6"	7"	11"	7 1/2"	2 1/2"	-	71
VB624-11	3	24"	13"	6"	7"	11"	9 1/2"	2 1/2"	-	8
VB636-11	4	36"	13"	6"	7"	11"	9 1/2"	2 1/2"	12"	122

Extra-Thick & Extra Length SAVE-T® Laminated Rubber Bumpers are available.

Other SAVE-T® Products

Strip Doors



Enclosures



Air Curtains



Bug Screen



Impact Doors



5350 Campbells Run Road • Pittsburgh, PA 15205-9738

800-888-9750

Tel: 412-787-9750 Fax: 412-787-3665

Web: www.tmi-pvc.com

E-Mail: customer-service@tmi-pvc.com



Copyright © 2010
 Catalog Number LDA-08-10